



Lock-In Amplifier User Manual

Lock-in amplifiers are versatile instruments that can be used to recover the magnitude and phase of weak oscillating signals buried under overwhelming noise. They are used in a vast range of applications including atomic physics, radio-frequency engineering, materials science, precision laser metrology and many more.





Table of Contents

Introduction	4
Principle of operation	4
User Interface	5
Main Menu	6
Signal Input	7
Dual-Phase Demodulator	8
Outputs	9
Advanced Configuration	10
Demodulation	11
Internal	11
External (direct)	11
External (PLL)	11
Auxiliary Output	12
Local Oscillator	12
Filtered Signal	13
Demod Signal	14
PID Controller	15
Off	15
Main Output	15
Auxiliary Output	16
PID Controller	17
Oscilloscope	18
Probe Points	19
Measurement Configuration	20
Acquisition	20
Trigger	21
Measurements	22
Cursors	22
Play / Pause	23
Full Screen Mode	23
Data Acquisition	24
Exporting Data	25
Measurement Traces	25
Acquired data	26
SD card	26
Dropbox	26



Example Measurement Configurations27

Measure magnitude and phase with respect to an external reference 27



Introduction

Lock-in amplifiers are extremely versatile instruments used primarily to recover the magnitude and phase of weak oscillating signals in the presence of overwhelming noise. They are used in a vast range of applications including atomic physics, radio-frequency engineering, materials science, precision laser metrology and many more.

Principle of operation

Lock-in amplifiers work by demodulating an input signal $R\sin(\omega t + \phi)$ with a reference signal $\sin(\omega t)$.

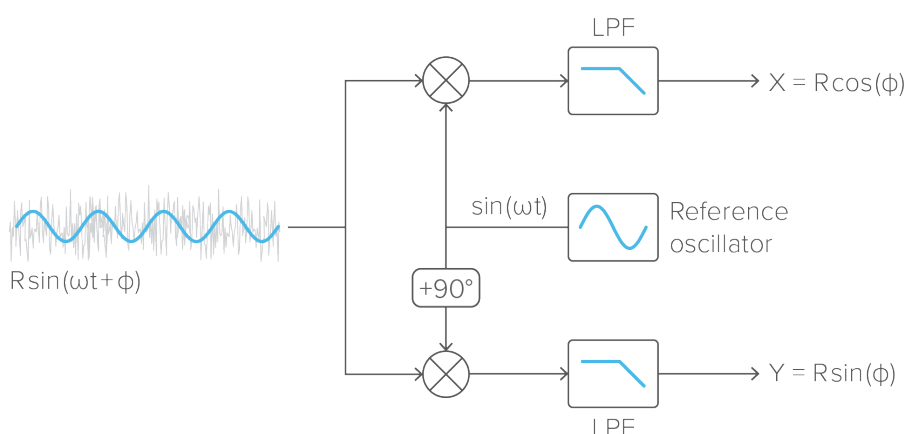

The demodulation process produces two spectral components: an *up-shifted* signal with a frequency equal to the sum of the input and reference signals, and a *down-shifted* signal with a frequency equal to the *difference* of the input and reference signals.

If the input and reference signals have the same frequency ω , then the down-shifted component will appear at DC and its phase will be equal to the difference between that of the input and reference signals, whereas the up-shifted component will appear at twice the input frequency with additive phase.

A low-pass filter is used to attenuate the up-mixed signal and to suppress noise, the output of which is proportional to the amplitude of the input signal scaled by the cosine of the phase difference: $R\cos(\phi)$. In order to reconstruct the magnitude and phase of the input signal, it is necessary to demodulate it with two orthogonal references, sine and cosine, to produce in-phase (X) and quadrature (Y) components relative to the reference. This process is referred to as dual-phase demodulation and is a standard feature of all modern lock-in amplifiers.

With X and Y, the magnitude R and phase ϕ can be calculated as $R = \sqrt{X^2 + Y^2}$ and $\phi = \tan^{-1}(Y/X)$.



User Interface

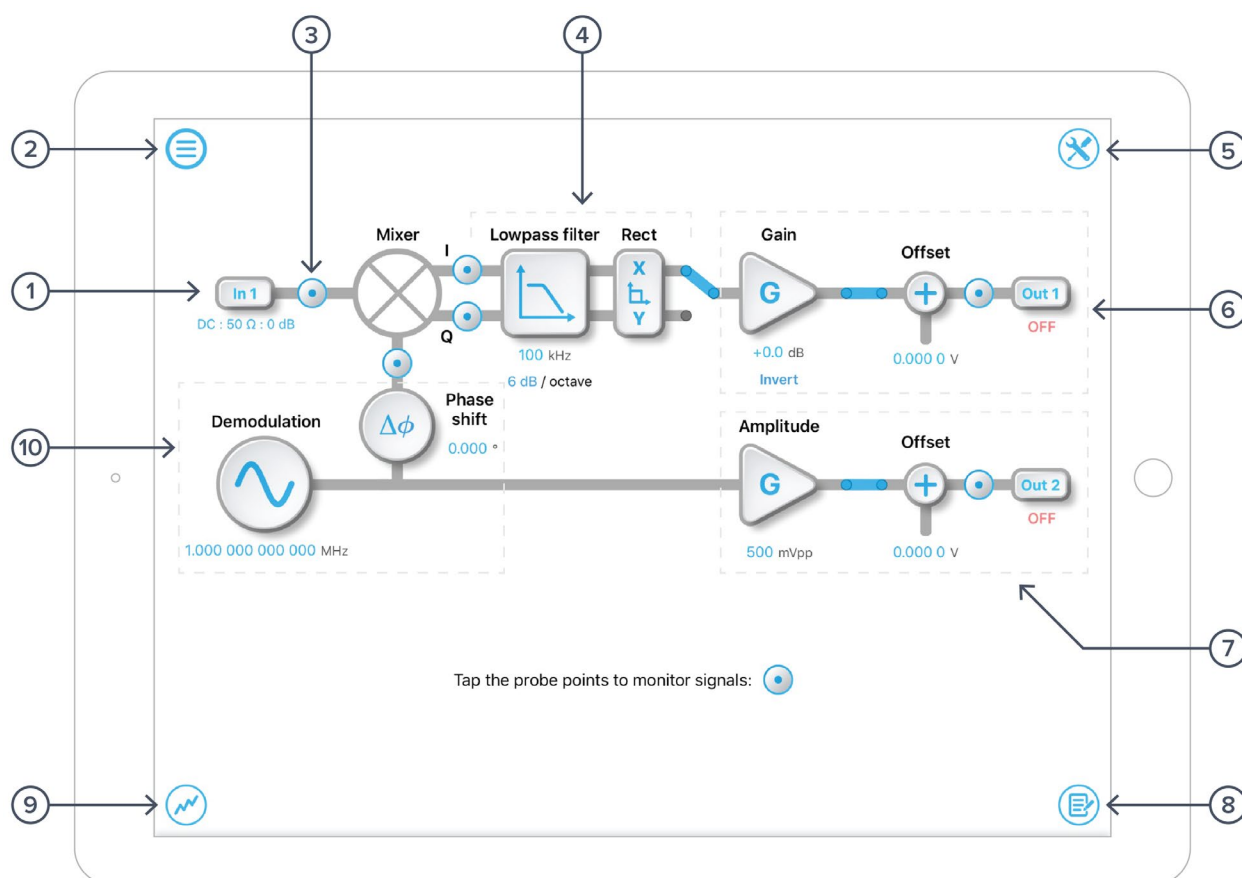

ID	Description	ID	Description
1	Input settings	6	Channel 1 output
2	Main menu	7	Channel 2 output
3	Probe point	8	Data logger
4	Filter settings	9	Oscilloscope
5	Advanced configuration menu	10	Demodulator



Main Menu

The **main menu** can be accessed by pressing the  icon, allowing you to:

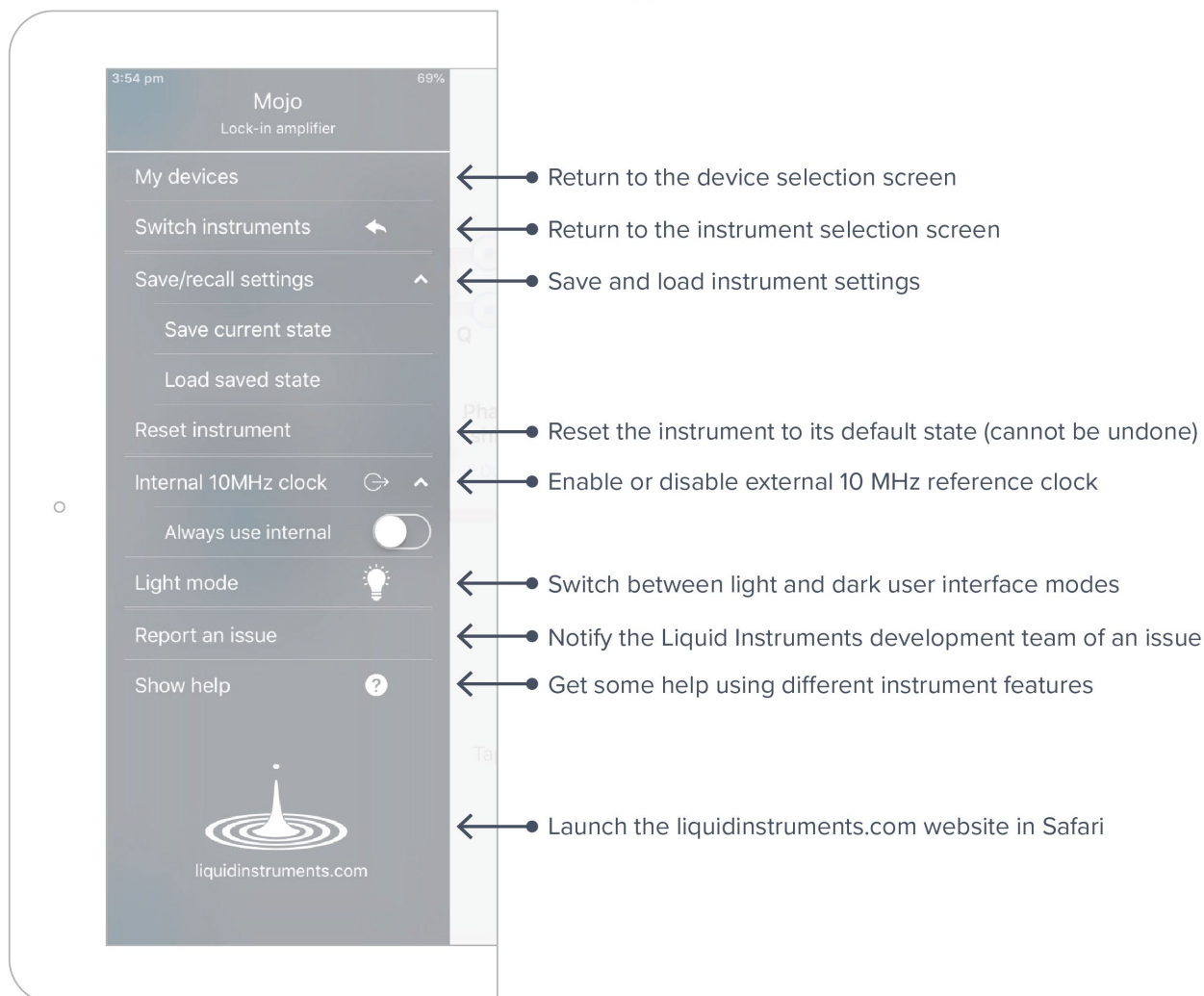

The screenshot shows the main menu of the Mojo Lock-in amplifier. The menu items and their functions are as follows:

- My devices**: Return to the device selection screen
- Switch instruments**: Return to the instrument selection screen
- Save/recall settings**: Save and load instrument settings
 - Save current state
 - Load saved state
- Reset instrument**: Reset the instrument to its default state (cannot be undone)
- Internal 10MHz clock**: Enable or disable external 10 MHz reference clock
 - Always use internal
- Light mode**: Switch between light and dark user interface modes
- Report an issue**: Notify the Liquid Instruments development team of an issue
- Show help**: Get some help using different instrument features

At the bottom of the menu is the Liquid Instruments logo and the website address liquidinstruments.com, which can be used to launch the website in Safari.



Signal Input

Tap the **In 1** icon to configure the input settings for the signal input.

Select between **AC** and **DC** input coupling

Select between **50 Ω** and **1 M Ω** input impedance

Select input gain (**+24 dB** and **+48 dB** are applied digitally)

In 1

DC : 50 Ω : 0 dB

Mixer

Coupling **DC**

Impedance **50 Ω**

Gain

-20 dB	0 dB
+24 dB	+48 dB

1.000 000 000 000 MHz



Dual-Phase Demodulator

The Moku:Lab's Lock-In Amplifier features a dual-phase demodulator with cascaded single pole low pass filters to attenuate the second harmonic and suppress noise in each quadrature.

- Select between **6 dB / octave** and **12 dB / octave** lowpass filter slopes
- Select between **rectangular (X/Y)** and **polar (R/ θ)** coordinate modes
- View the demodulated in-phase and quadrature signals prior to the low-pass filters using probe points
- Select which demodulated signal to route to the output. Note: your options depend on how the lock-in amplifier is configured.

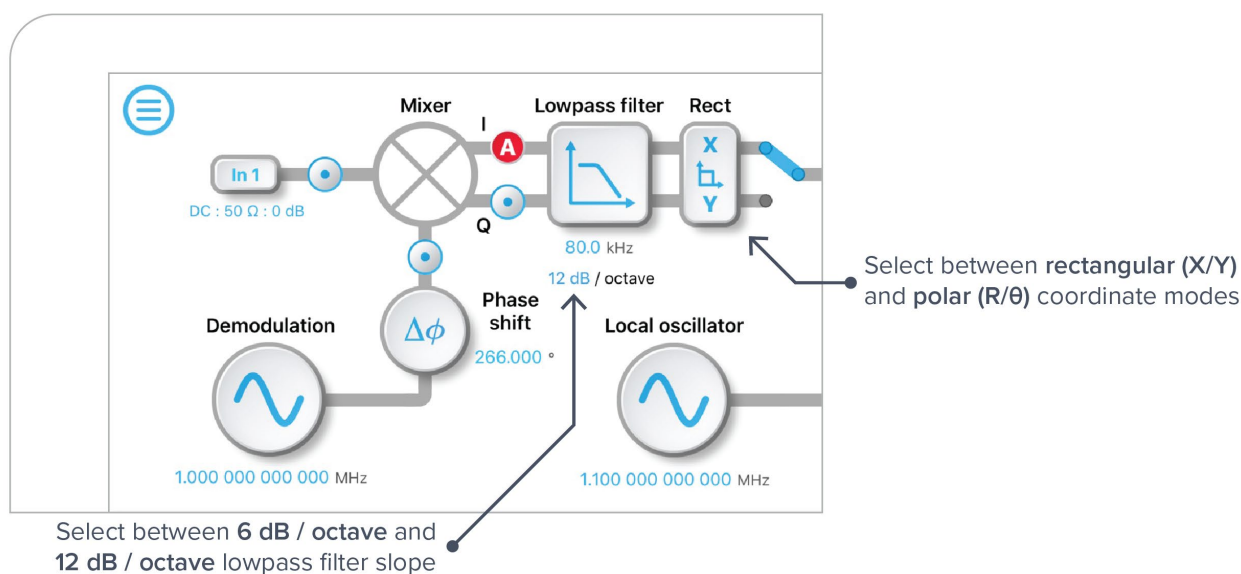

Rectangular (or Cartesian) coordinate mode measures the input signal with respect to a specific quadrature of the reference signal. When combined with a PID controller, Cartesian mode can be used to perform laser frequency stabilization.

Polar coordinate mode measures the amplitude and phase of the input signal with respect to the reference signal. Polar mode is not available for external references configured in straight-through mode.



Outputs

Configure the gain / amplitude and voltage offset of the two output channels. Enable / disable either output channel by tapping the **Out 1** and **Out 2** icons. View the signal at the output of each channel using the probe points

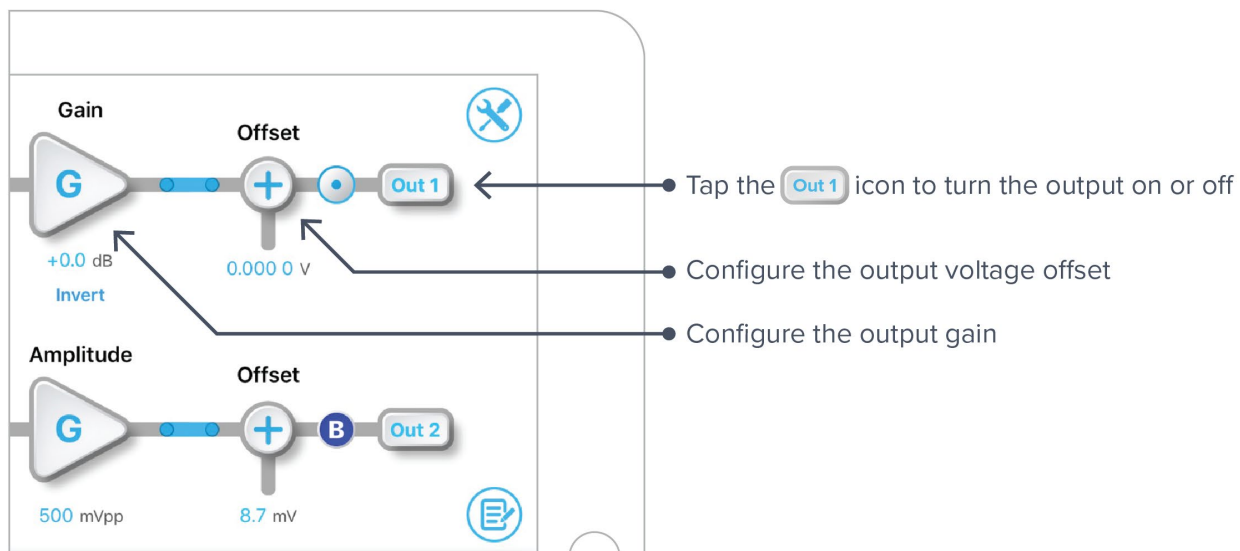



Advanced Configuration

The lock-in amplifier's digital signal processing layout can be rapidly re-configured to suit different applications by accessing the advanced configuration menu using the  icon at the top right of the block diagram.

- Select between internal, external (straight-through) and external (phase-locked) demodulation references
- Configure the auxiliary output to generate an independent local oscillator with adjustable frequency and amplitude, the second output from the demodulator (e.g., generate voltage signals proportional to R and θ from outputs 1 and 2 respectively), or the demodulation reference (available in internal demodulation mode only)
- Select whether to include a PID controller on the main output (channel 1) or the auxiliary output (only available when generating a second filtered signal from the auxiliary output)

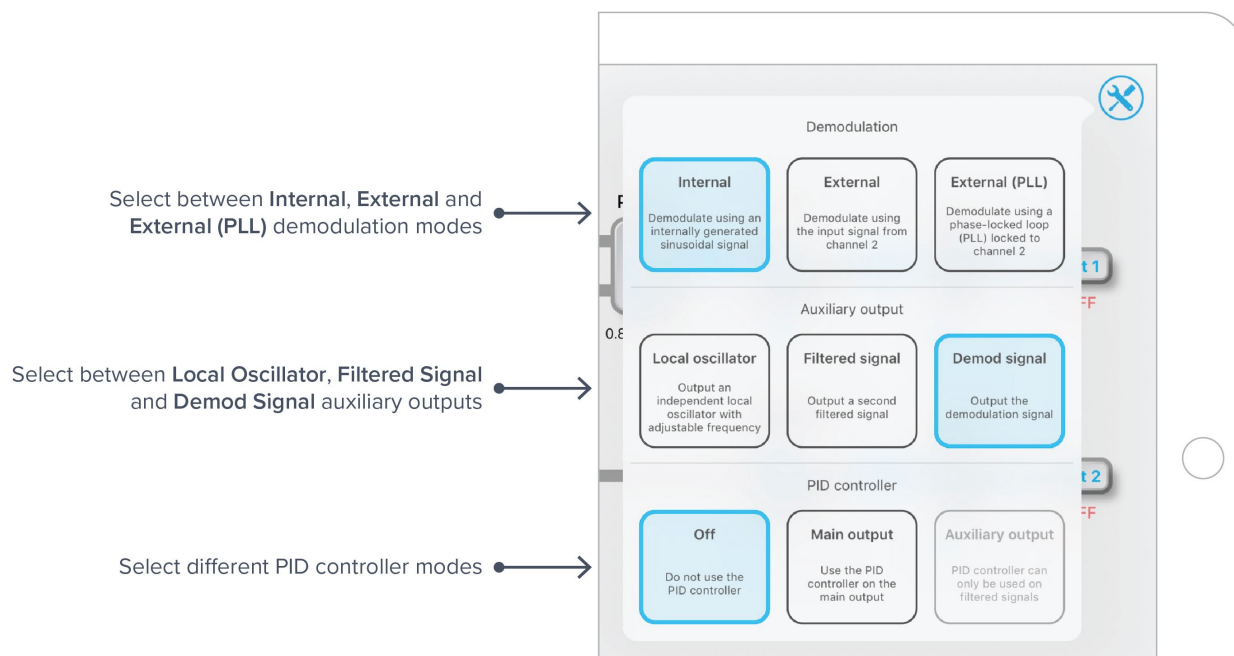



Demodulation

The demodulation mode determines which reference signal is used to demodulate the input signal.

Internal

The input signal can be demodulated with an internally generated reference signal. This *local oscillator* is derived from the Moku:Lab's internal clock and thus shares the same time-base. The frequency range of the internal reference is 1 MHz to 200 MHz.

To measure the phase of the input signal relative to the reference, Moku:Lab's time-base. This can be done in two ways:

1. Using the internal local oscillator to drive the external system
2. Phase-locking the Moku:Lab to the external reference using the 10 MHz reference loop

External (direct)

The input signal can be demodulated by a direct external reference, permitting the use of non-sinusoidal demodulation of the input signal. This can be used to measure correlation or to recover specific components of complex input signals.

The arbitrary nature of direct external reference signals mean that they cannot be used to perform dual-phase (orthogonal) demodulation of the input signal. This prevents external (direct) demodulation mode from being used to measure Y , R and θ since only one quadrature can be interrogated.

External (PLL)

Dual-phase demodulation of the input signal with an external reference can be performed using phase-locked external reference mode, which constructs two orthogonal reference signals phase-locked to the external reference. This mode uses a digitally implemented phase-locked loop to track the phase of the external reference with a bandwidth of 10 kHz, allowing it to generate phase-locked in-phase and quadrature sinusoids at the same frequency and with adjustable phase.

External (PLL) mode enables the lock-in amplifier to recover information in all quadratures (X/Y and R/θ) without requiring the Moku:Lab to share the same time-base as the external system.

The phase-locked loop will automatically lock to the strongest harmonic of the external reference in the range of 500 kHz to 200 MHz. The reacquire button can be used to re-lock to the external reference.



Auxiliary Output

The Moku:Lab's second output can be configured to generate an additional auxiliary voltage signal.

Local Oscillator

Local oscillator mode allows you to generate a sinusoidal signal with independently configurable frequency, amplitude, and voltage offset. The frequency can be adjusted from 1 MHz to 200 MHz and the amplitude range (amplitude + offset) is $2 V_{pp}$ with 1 mV resolution.

The generated waveform shares the same time-base as the rest of the instrument. When used with internal demodulation, this mode can be used to stimulate a system at one frequency and demodulate at a different frequency, for example in wavelength modulation spectroscopy where it is necessary to demodulate harmonics of the input signal.

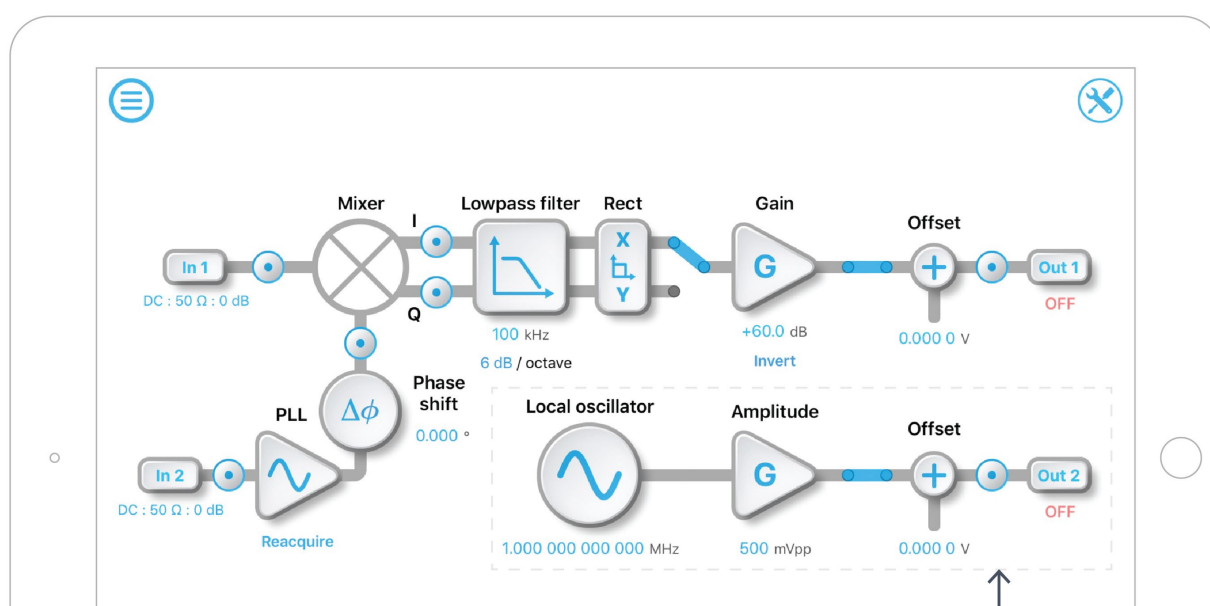

The local oscillator auxiliary output mode allows you to generate a local oscillator signal with independent frequency, amplitude and vertical offset control



Filtered Signal

The second output of the dual-phase demodulator can be routed to the Moku:Lab's second output channel to produce a voltage signal proportional to Y or θ .

This mode can be used to record both quadratures at the same time using probe points.

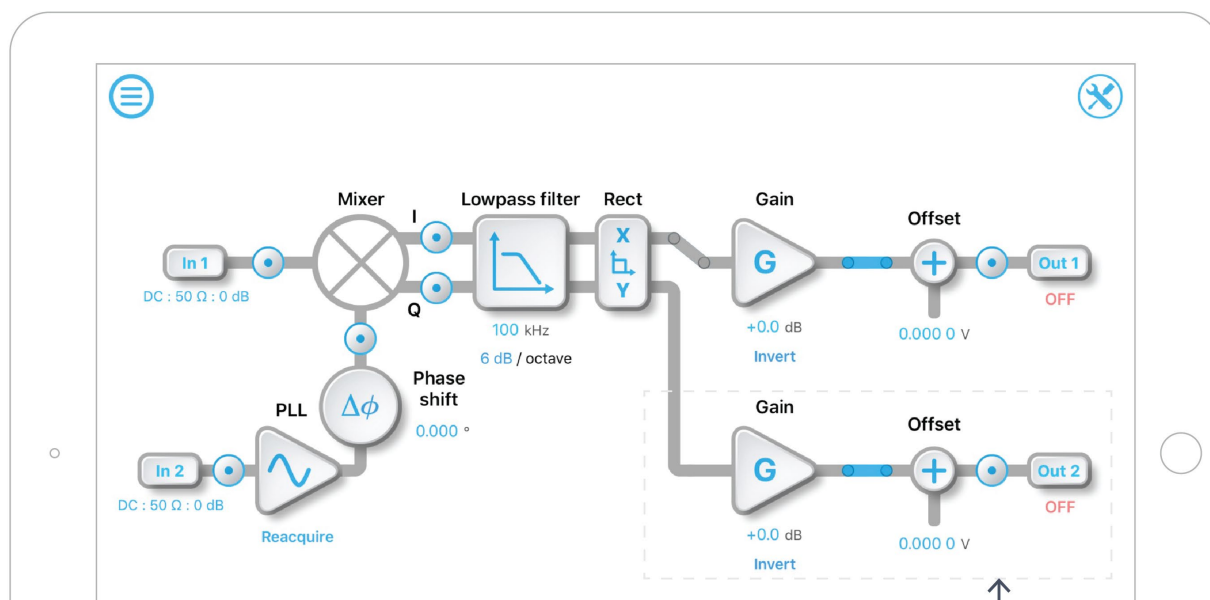

The filtered signal auxiliary output mode generates a second voltage signal proportional to the second lowpass filtered output of the demodulator



Demod Signal

The internal reference used to demodulate the input signal can be used to generate a sinusoidal waveform at the same frequency with configurable amplitude and voltage offset.

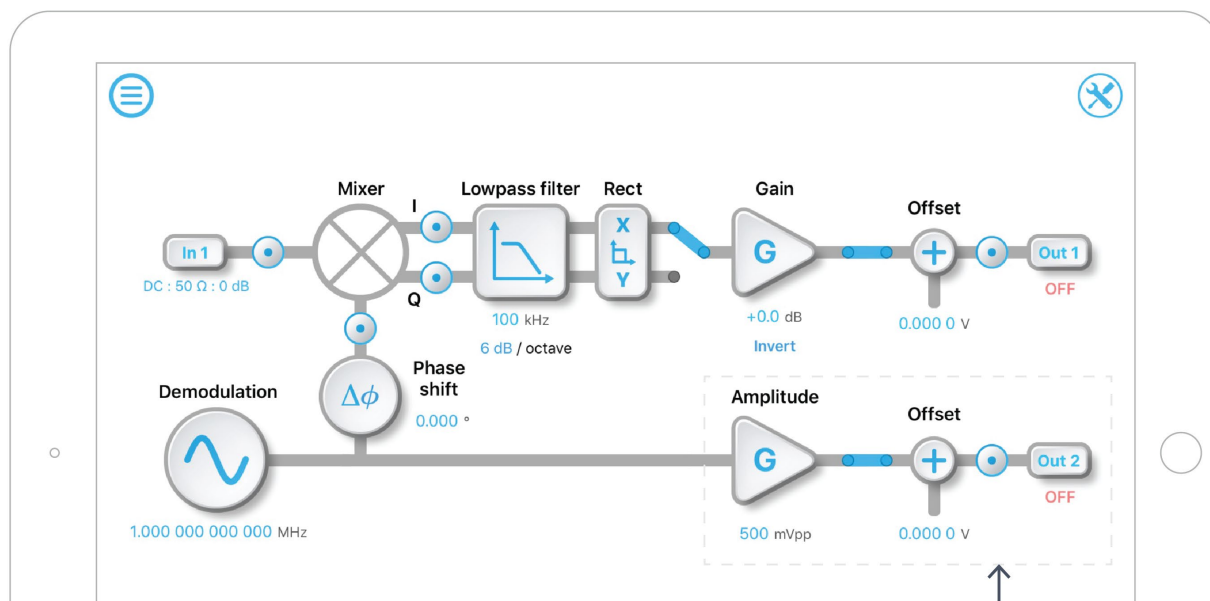

The demod signal auxiliary output mode will generate a local oscillator at the same frequency as the demodulation waveform with full amplitude and vertical offset control



PID Controller

The Moku:Lab's Lock-In Amplifier can be used to control an external system by acting as both a sensor and controller using a dedicated PID controller. The PID controller's frequency dependent gain can be easily configured to satisfy the stability requirements of the control system.

Note: The lock-in amplifier can only implement a single PID controller at a time. This means that when the instrument's auxiliary output is configured to generate a voltage signal proportional to the Y or θ , the PID controller can be used on *either* X/R or Y/θ , but not both.

Off

Turns off the full PID controller. A flat gain can still be configured.

Main Output

Adds a PID controller to the main output.

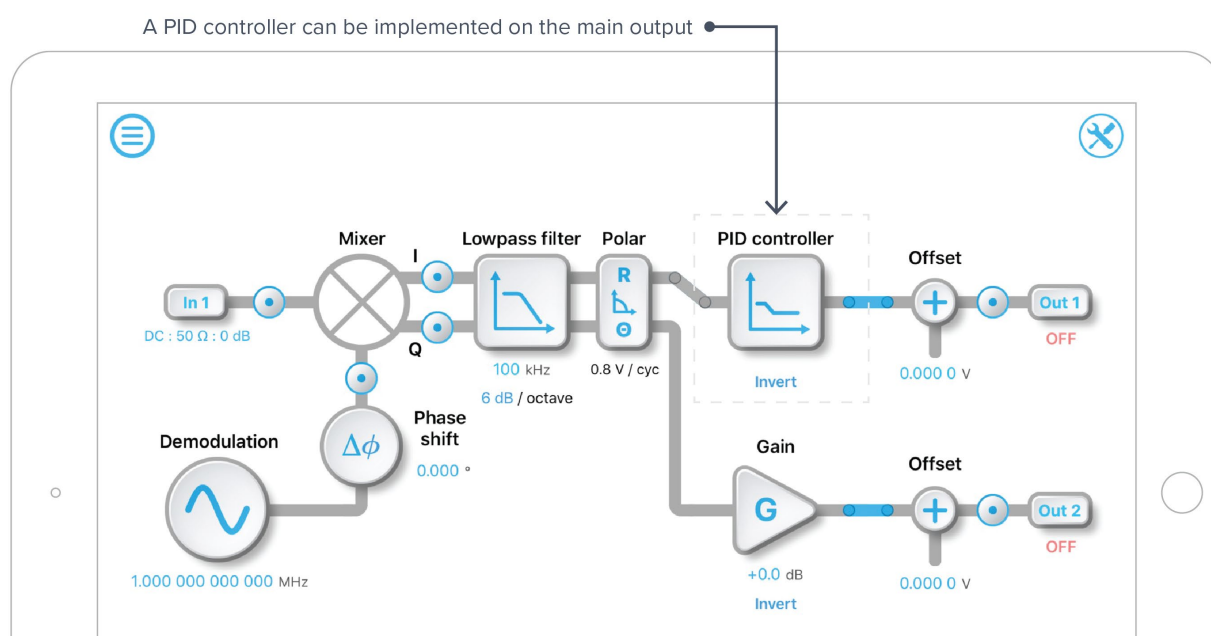



Auxiliary Output

Adds a PID controller to the auxiliary output.

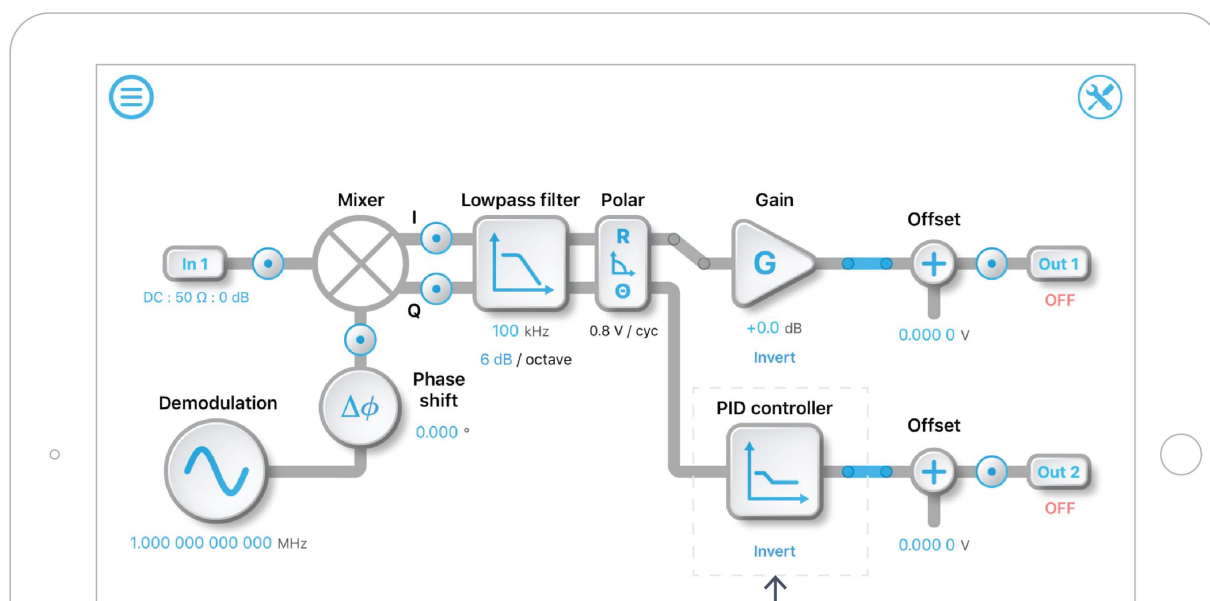

A PID controller can be implemented on the auxiliary output



PID Controller

The PID controller provides full control over proportional, integral and derivative gain profiles with saturation levels available for the integral and derivative controllers. The PID's transfer function is updated in real-time.

The gain of each control stage can be adjusted using touch gestures on the iPad interface. The following example shows a proportional plus integral controller with a unity gain crossover frequency at 150 Hz. It is possible to maintain this crossover frequency with the proportional gain by using the **Overall gain** control on the right, which will shift the entire gain profile up and down.





Oscilloscope

Moku:Lab's Lock-In Amplifier includes a built-in oscilloscope, enabling you to observe and record data of up to two signals in the lock-in amplifier's signal processing chain at a time.

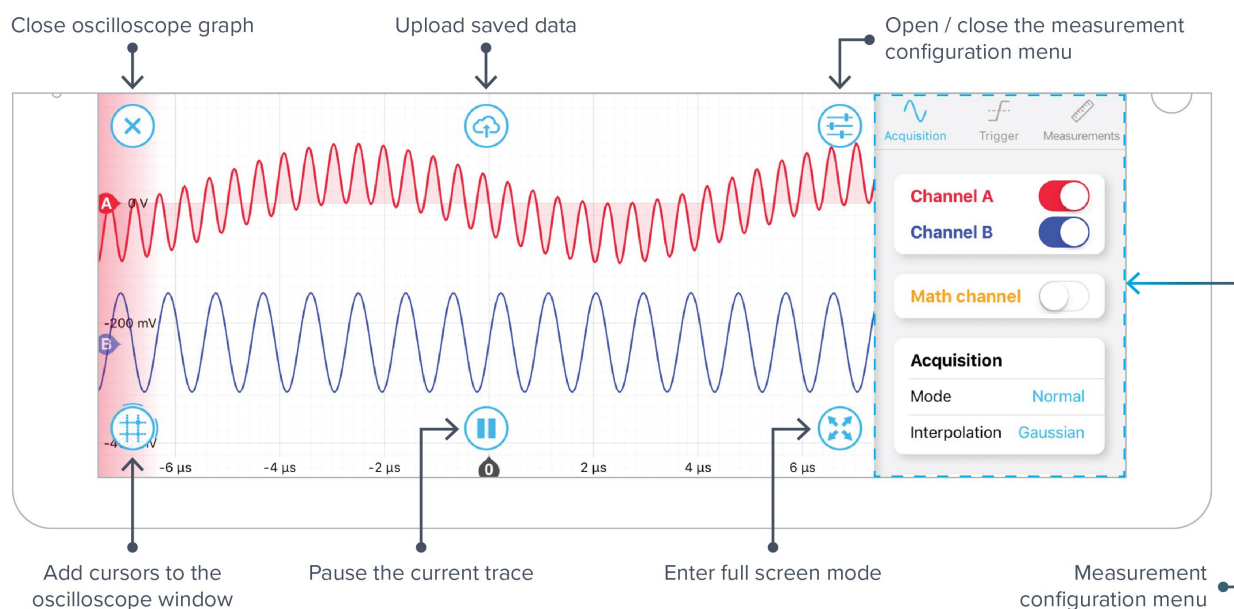

The oscilloscope will appear automatically when a probe point  is activated.

You can hide the oscilloscope by pressing the  icon and reveal it by pressing the  icon.



Probe Points

Add probe points  to view signals at different locations in the digital signal processing chain.

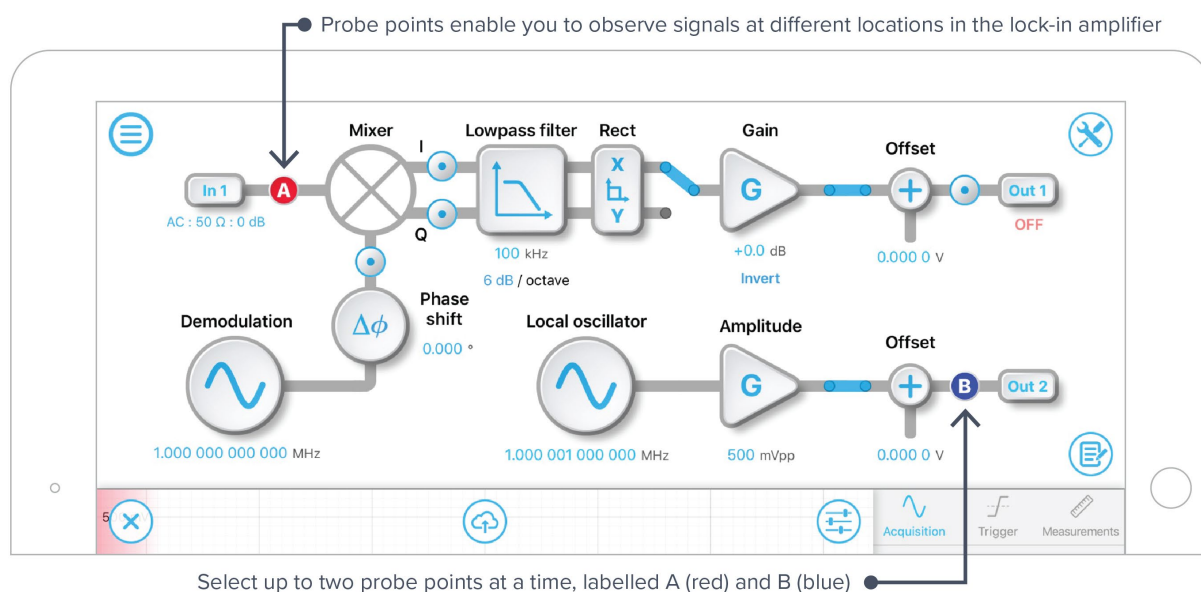



Measurement Configuration

The measurement configuration menu allows you to configure the oscilloscope's acquisition, trigger and measurement settings.

Access the measurement configuration menu by pressing the  icon.

Acquisition

Display the measurement configuration menu which will appear on the right of the iPad screen

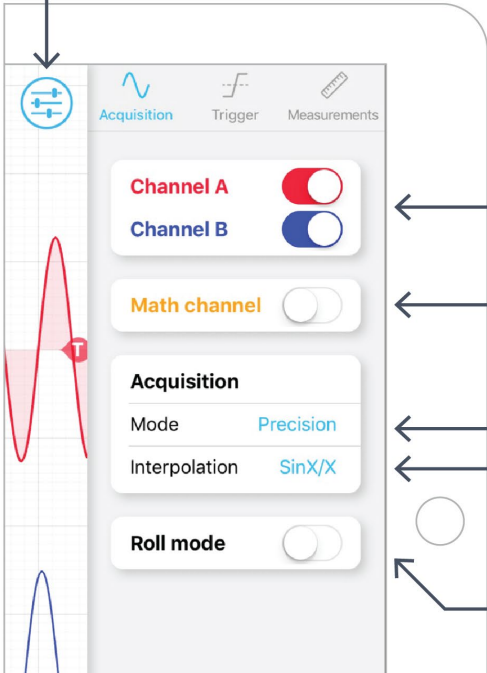

- Select which probe to display on the oscilloscope
- Display a math channel on the oscilloscope
- Select between **Normal** and **Precision** acquisition modes
- Select between **SinX/X**, **Gaussian** and **Linear** interpolation
- Display oscilloscope signals in roll mode



Trigger

← ● Select between **Auto** and **Normal** trigger modes

← ● Select which channel to trigger on

← ● Configure **Nth event** triggering mode

← ● Set the trigger's holdoff time (0 to 10 seconds)

← ● Select between **Edge** and **Pulse** trigger types

← ● Configure the desired behaviour of the trigger

← ● Set the trigger level

← ● Select **Auto** or **Manual** trigger sensitivity

← ● Activate **Noise Reject** or **High Frequency Reject**

Tip: Quickly adjust trigger settings by tapping the trigger marker 



Measurements

The measurements menu  allows you to measure up to seven attributes at a time across both input channels and the math channel.

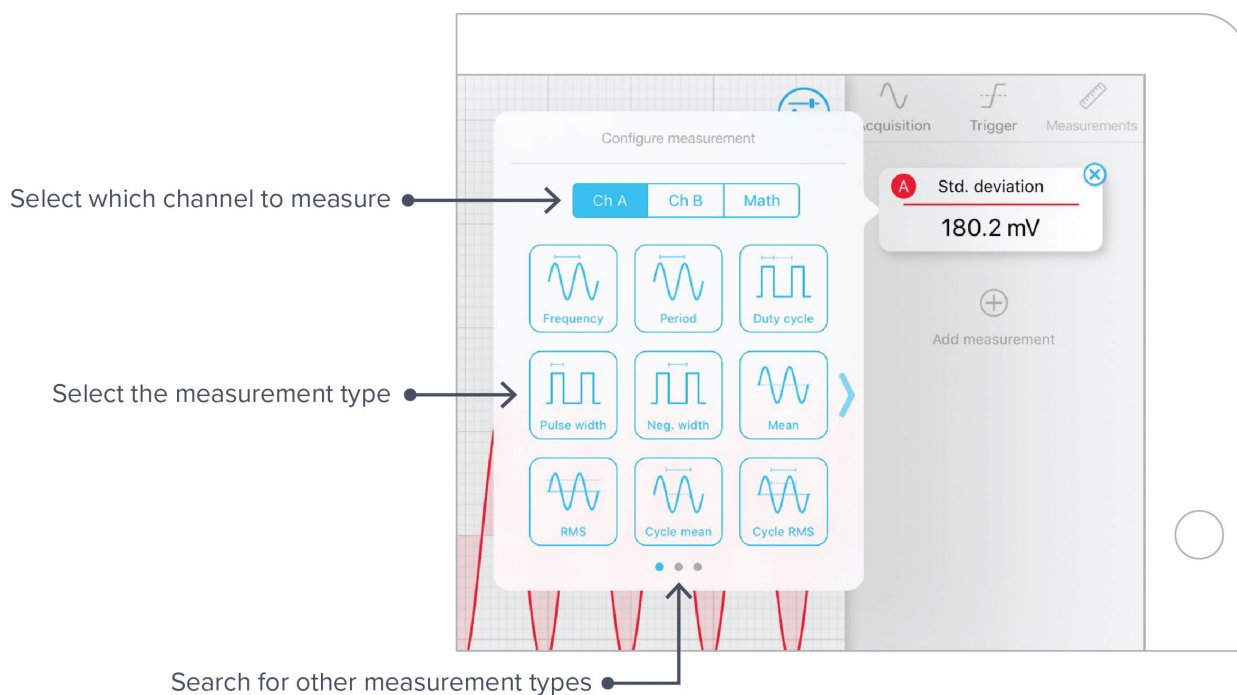
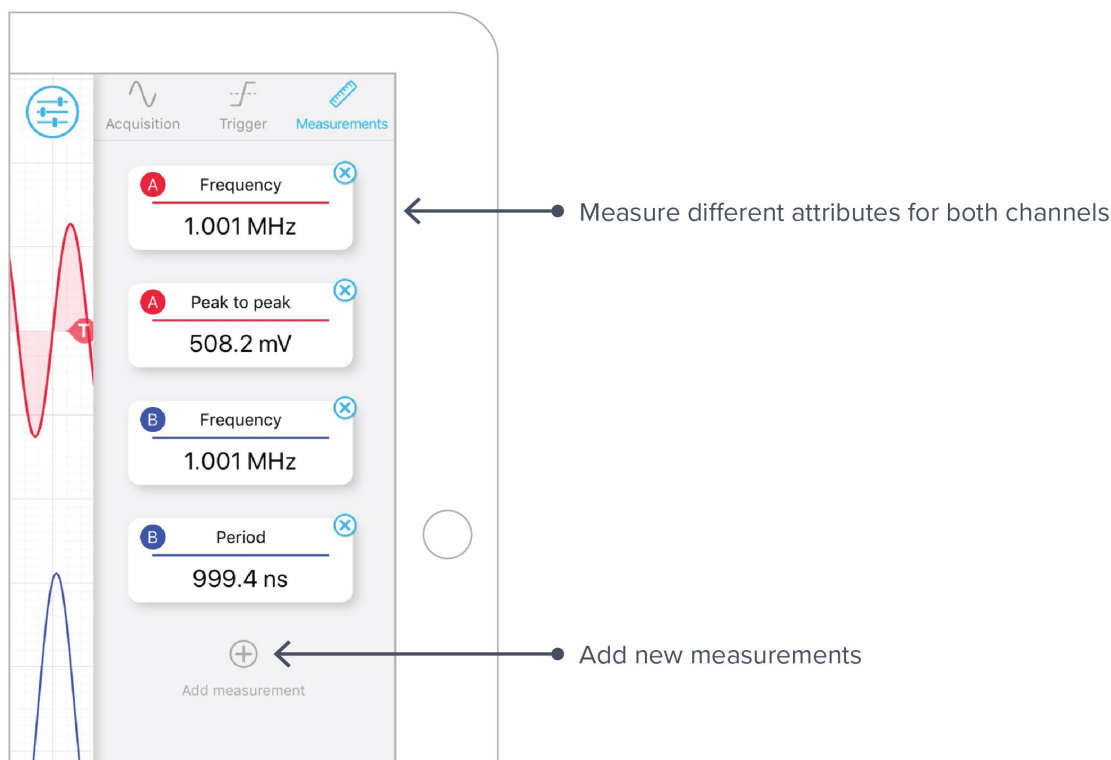



Cursors

Voltage and Time cursors can be added to the measurement trace by pressing the  icon.





Tip: Quickly add voltage cursors by dragging your finger up from the cursor icon. Add time cursors by dragging your finger to the right away from the icon.

Play / Pause

The measurement trace can be paused at any time by pressing the  button. This allows you to closely inspect features in the most recently captured trace. No new measurement data will be displayed until the measurement is resumed by pressing the  icon.

Pressing the “Share” button will also pause capture and must be resumed from this button.

Full Screen Mode

Press the  icon to enter full screen mode. Exit full screen mode by pressing .



Data Acquisition

Acquire data from up to two probe points at a time at a maximum sampling rate of 500 kS/s for two channels and 1 MS/s for one channel. To access the data acquisition menu, press the  icon.

Data can be acquired in one of two acquisition modes, Normal and Precision. Precision mode filters channel data according to the selected acquisition rate, increasing vertical resolution and attenuating aliased harmonics.

- Data can be saved to SD card or RAM with binary *.li or comma separated value *.csv file formats
- Files saved to RAM will be lost when the Moku:Lab is powered down or reset
- Files saved with binary *.li format can be converted to *.csv or *.mat using Liquid Instruments file conversion software (<https://github.com/liquidinstruments/lireader>)
- Record data for up to 240 hours, and delay the start of a measurement for up to 240 hours
- Start a measurement by pressing the red circle

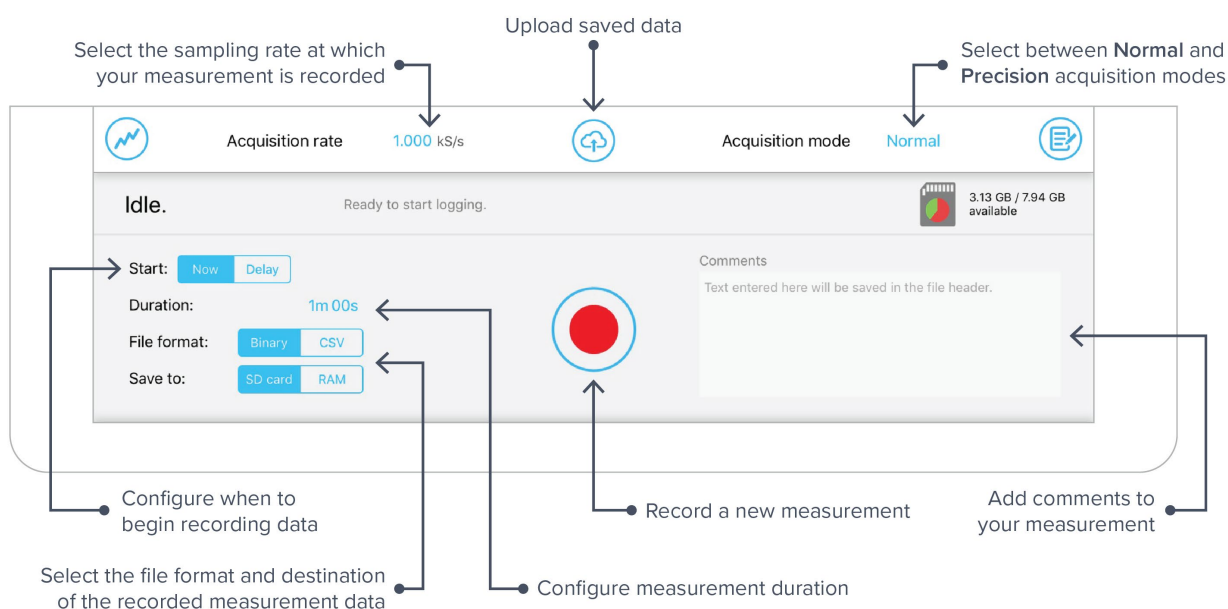

Note: As a precaution, you will be warned about switching instruments while a measurement is taking place.



Exporting Data

Export data by pressing the  icon.

Measurement Traces

Measurement traces can be uploaded to My Files (iOS 11 or later), Dropbox, E-mail, SD card, iCloud, Clipboard (screenshot is not copied to the clipboard).

To export a measurement trace, press the  icon on the oscilloscope.

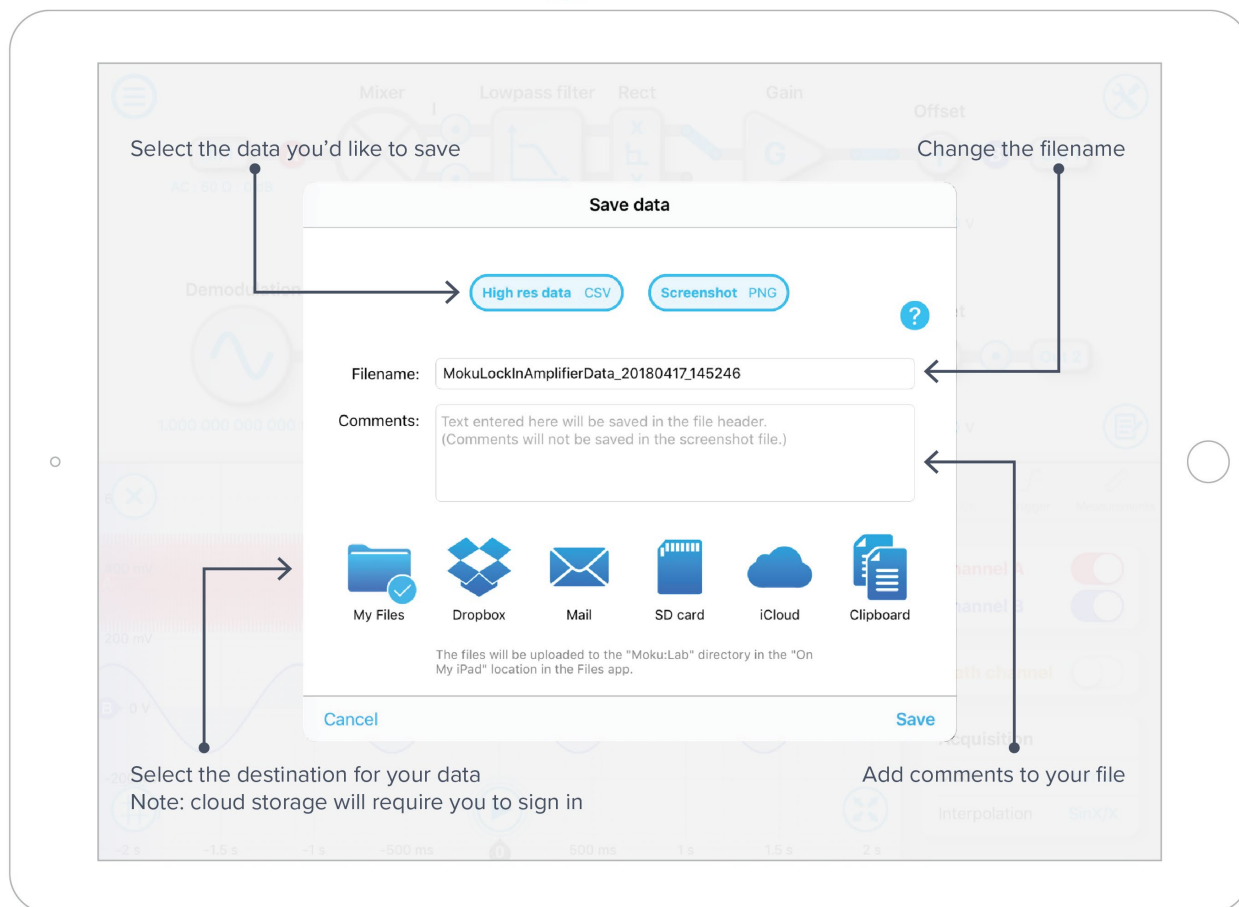



Acquired data

Data that has been acquired to SD card or RAM can be uploaded to My Files (iOS 11 or later), Dropbox, E-mail, and iCloud.

To export acquired data, press the  icon in the data logger.

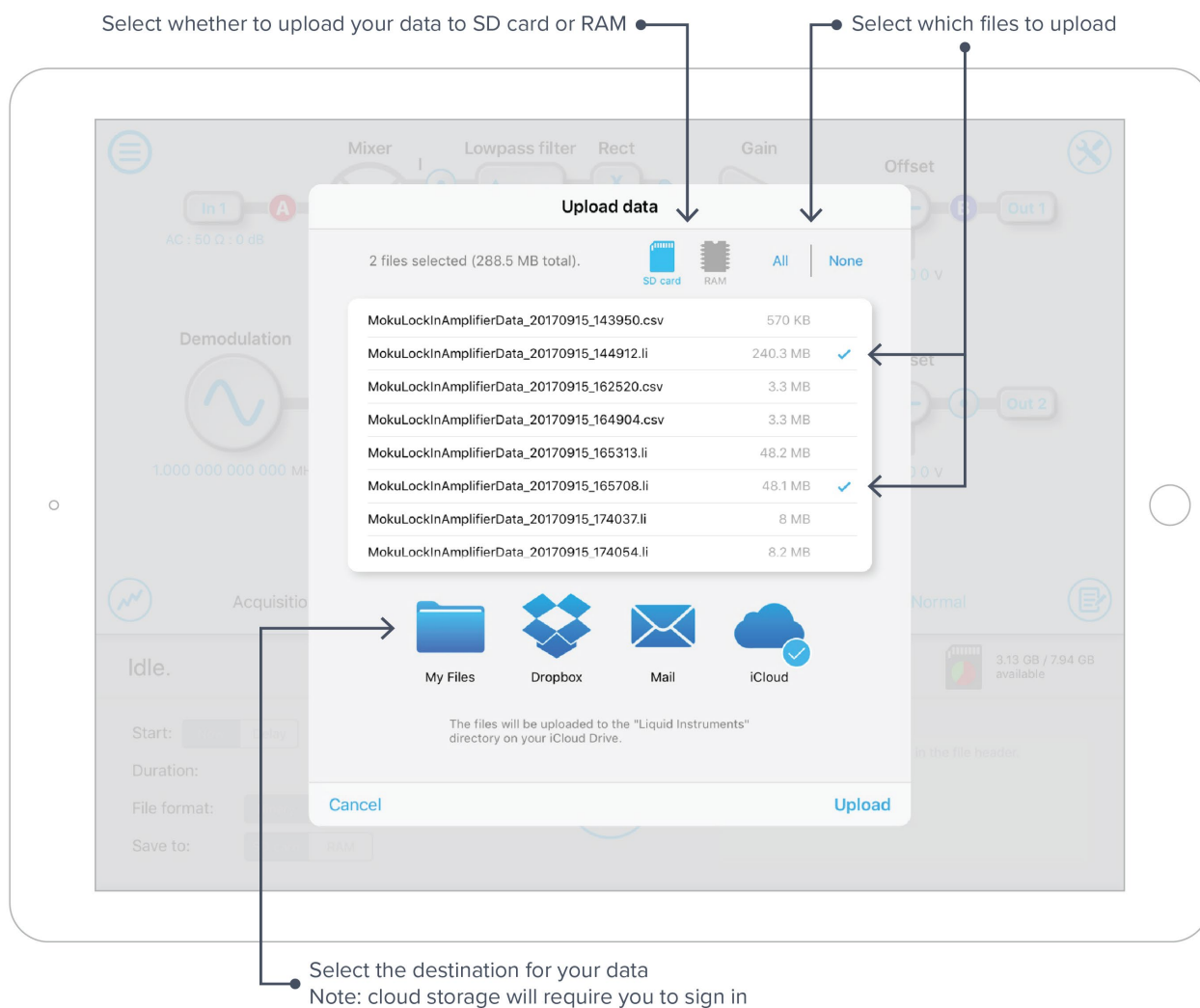

SD card

- Upload files to SD card by inserting a compatible FAT32 formatted drive into the Moku:Lab's SD card slot, located on the rear of the device next to the power connector.

Dropbox

- Upload files to Dropbox by logging in to your account with the Moku:Lab iPad app.



Example Measurement Configurations

Measure magnitude and phase with respect to an external reference

To measure the magnitude and phase of the input signal with respect to an external reference:

1. Configure the input coupling, impedance and gain to suit your measurement 

2. Set the demodulation mode to **Polar**



Access the Advanced Configuration Menu  and

3. Set demodulation to **External (PLL)**
4. Set auxiliary output to **Filtered signal**
5. Set PID controller to **Off**

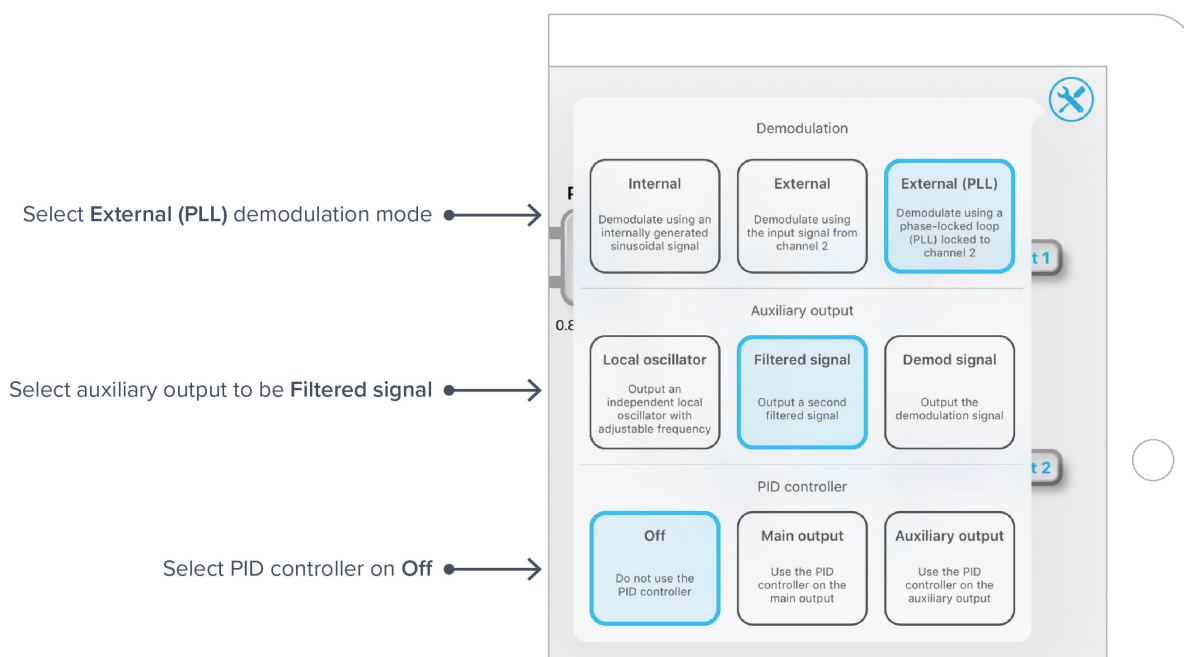



6. Place probe points at the two outputs

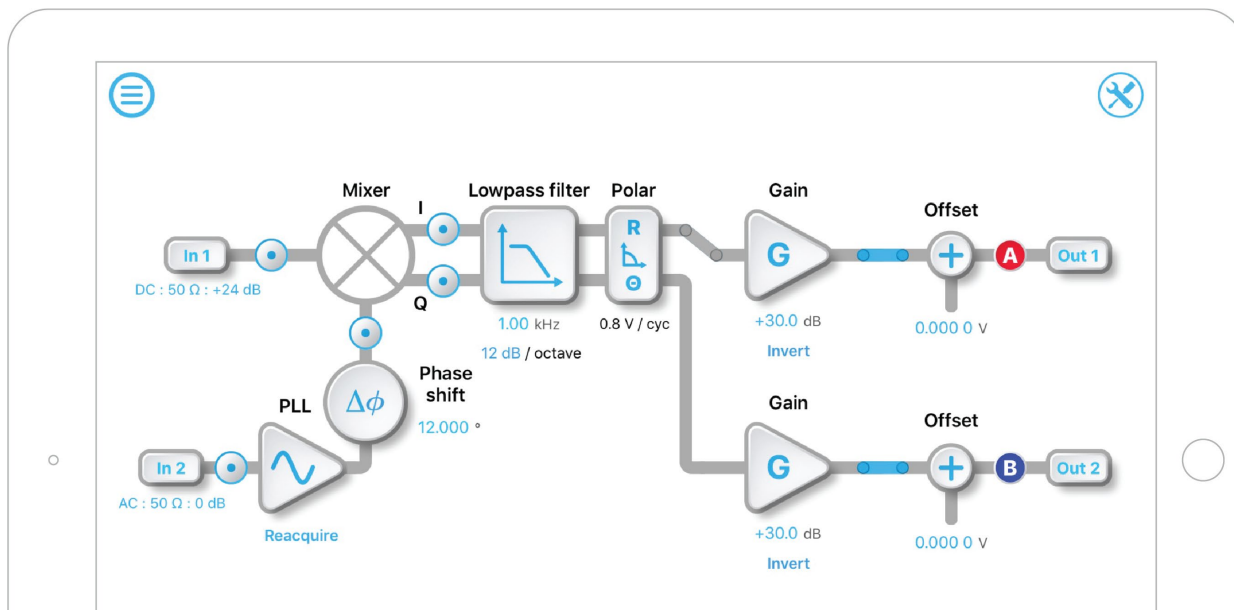

7. View the time-series magnitude and phase data using the lock-in amplifier's in-built oscilloscope.

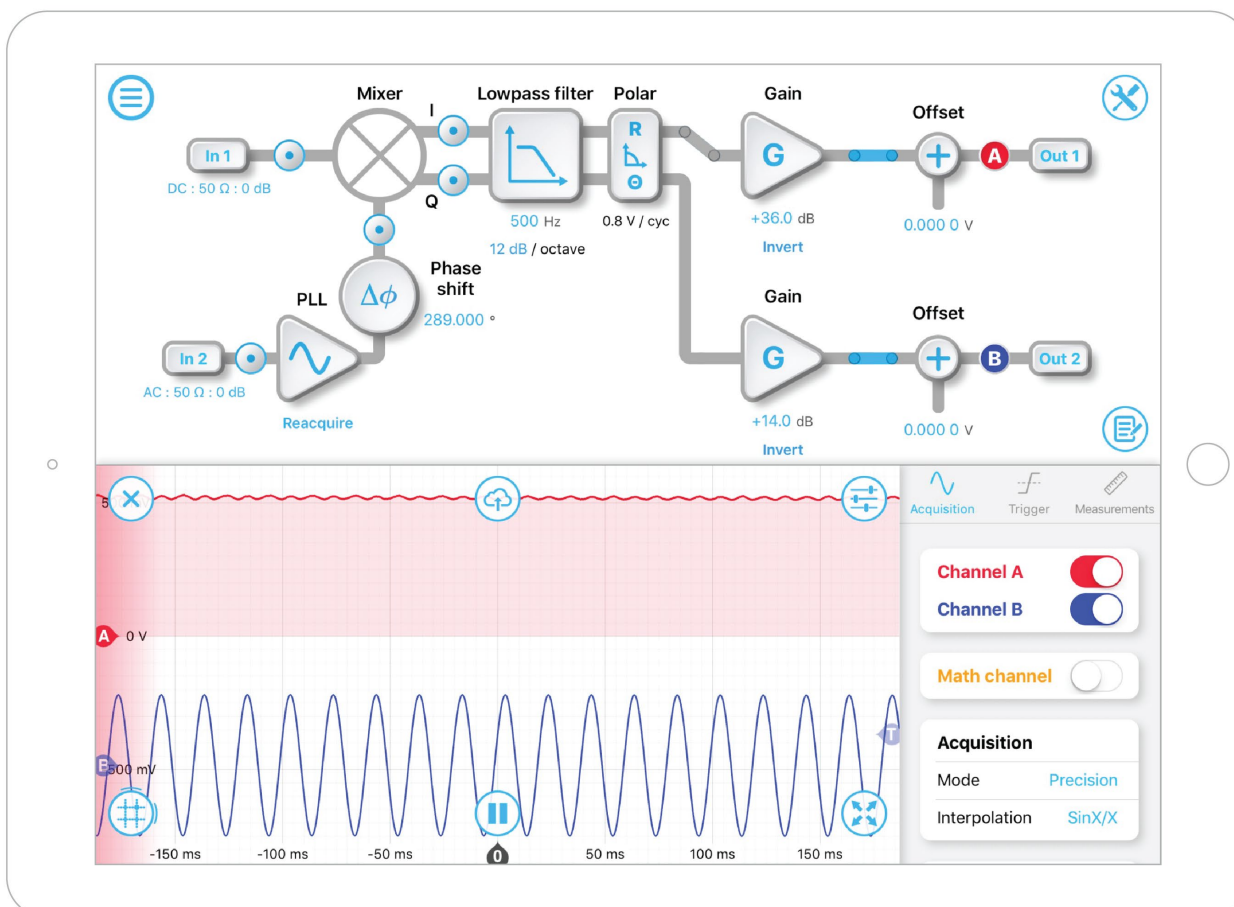

8. Tune the gain values in each arm to balance precision and measurement range.